

LTSI SERIES

IMPORTANT SAFEGUARDS

When using electrical equipment, basic safety precautions should always be followed, including the following:

THIS PRODUCT MUST BE INSTALLED IN ACCORDANCE WITH THE APPLICABLE INSTALLATION CODE BY A PERSON FAMILIAR WITH THE CONSTRUCTION AND OPERATION OF THE PRODUCT AND THE HAZARDS INVOLVED. CE PRODUIT DOIT ÊTRE INSTALLÉ SELON LE CODE D'INSTALLATION PERTINENT, PAR UNE PERSONNE QUI CONNAÎT BIEN LE PRODUIT ET SON FONCTIONNEMENT AINSI QUE LES RISQUES INHÉRENTS. DISCONNECT POWER TO ALL CIRCUITS BEFORE WIRING FIXTURE. INSTALL IN ACCORDANCE WITH ALL NATIONAL, STATE, AND LOCAL CODES. DO NOT CONNECT TO AN UNGROUNDED SUPPLY. READ ALL FIXTURE MARKINGS AND LABELS TO ENSURE CORRECT INSTALLATION OF FIXTURE. SUPPLEMENTAL INSTRUCTIONS MAY BE LOCATED ON THE FIXTURE, IN ADDITION TO THIS INSTRUCTION SHEET, REGARDING ORIENTATION, OR MOUNTING RESTRICTIONS.

SAVE THESE INSTRUCTIONS

The LuxTran LTSI series luminaires contains sensitive electronics. Take care to avoid damage by improper handling or static electricity discharge (ESD). Either type of damage could render the system inoperable or cause latent failure.

INSTALLATION INSTRUCTIONS

1. Secure fixture to wall or ceiling using user supplied hardware. 3/8 × 1-3/8 slots in mounting brackets are provided. See Figure 1.

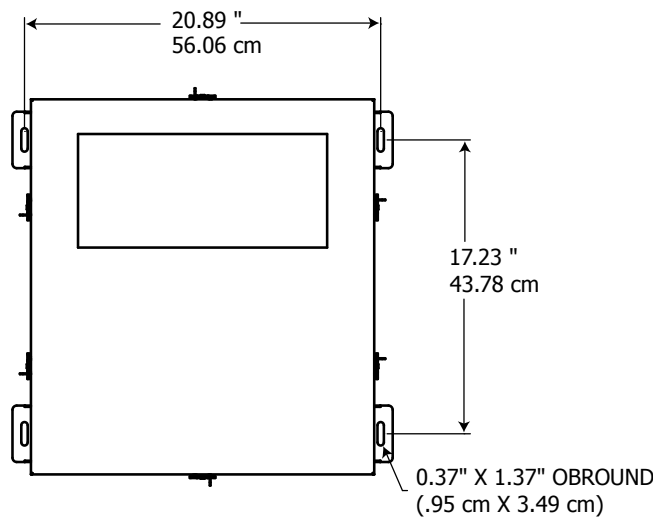

Figure 1

NOTE: If the fixture has directional optics, note the label indicating the direction of light and install appropriately.

2. Rotate latches and open door, which is retained by stainless steel cables.
3. Loosen wing nuts and remove Wiring Cover. See figure 2.

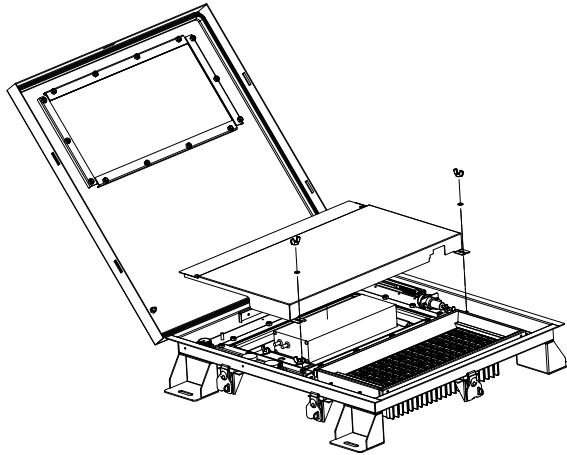

Figure 2

4. Connect weather tight electrical service to 1/2 or 3/4 conduit hole provided.
5. Connect electrical service:
 - Black- input line, 277-480VAC
 - White- Neutral
 - Copper- ground
6. Replace Wiring Cover and secure with wing nuts.
7. Close door and secure rotating latches.

SERVICE INSTRUCTIONS

Before beginning any service operation, be sure the power to the fixture is off.

To Replace an LED Driver:

1. Rotate latches and open door, which is retained by stainless steel cables.
2. Loosen wing nuts and remove Wiring Cover. See figure 2.
3. Loosen the latch screws and remove the retaining latch bracket to free the driver.
4. Replace the driver and secure by reversing steps 1-4 above.

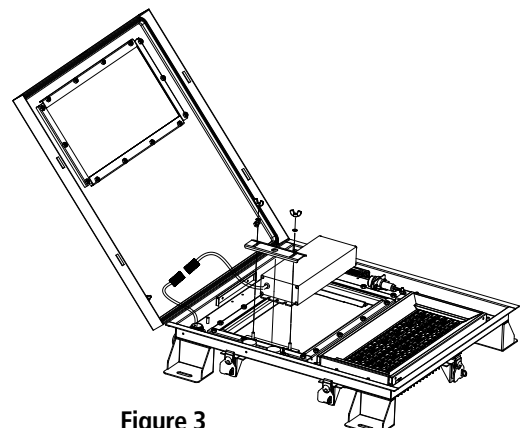

Figure 3



To Replace LED Modules:

LED module replacement may be done after the fixture is removed from service.

The heat sinks and optics must also to be replaced when replacing the LED modules.

1. Rotate latches and open door, which is retained by stainless steel cables.
2. Remove reflectors.
3. Loosen the nuts retaining the LED module assemblies.
4. Replace the LED module assembly by reversing steps 1-4 above.

NOTE: Torque lock nuts at 30 inch pounds.

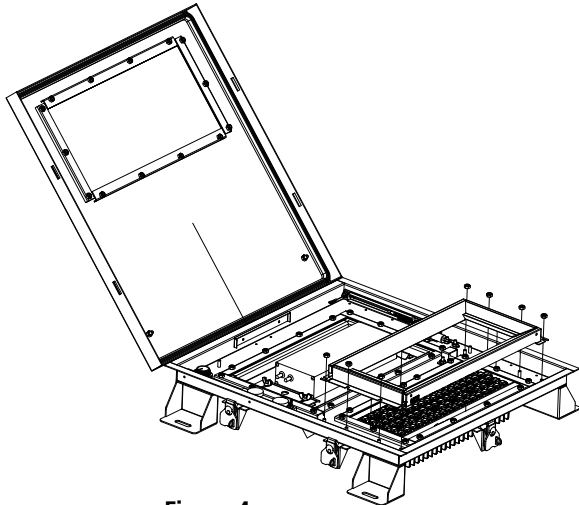

Figure 4

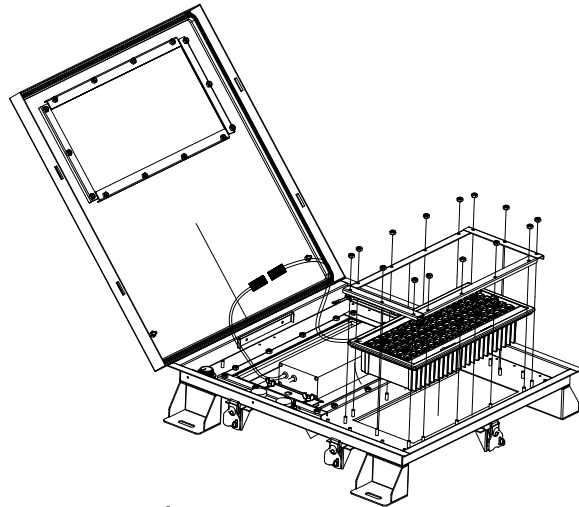

Figure 5

CUSTOMER SERVICE

For technical assistance, call 1-800-4KENALL (1-800-453-6255).

WARRANTY

For warranty information visit www.kenall.com/Resources/Certified-Performance-Warranties

