

# MEDMASTER™ MRI REMOTE POWER SUPPLY/FILTER SYSTEM

## MRIPSF SERIES

### PRODUCT FEATURES:

- » Remote-mounted power supply and EMI filter compatible with all Kenall MRI luminaires
- » Provides 24VDC supply with 120W, 240W, or 480W capacity
- » Filter provides >100dB attenuation from 5MHz to 10 GHz



### PROJECT INFORMATION

Job Name \_\_\_\_\_

Fixture Type \_\_\_\_\_

Catalog Number \_\_\_\_\_

Approved by \_\_\_\_\_

### SPECIFICATIONS - POWER SUPPLY

**MECHANICAL:** Die-formed cold-rolled steel electrical enclosure with cooling apertures and white TGIC powder coat finish. Includes (7) 7/8" and (7) 1-1/8" knock-outs for the AC supply and 24VDC output to EMI filter.

**ELECTRICAL:** 120-277 VAC, 50/60Hz electrical input; 24VDC nominal constant-voltage output. Over-current, short-circuit, over-voltage, and over-temperature protection. For additional electrical specifications for each power supply, please refer to Electrical Specifications Chart.

**INSTALLATION:** Must be installed outside the shielded MRI environment. Contains ferrous components and power regulation components that can damage or interfere with MRI equipment. Must be used in conjunction with the provided EMI filter. Must be installed in a dry environment with a surrounding ambient temperature below 104°C (40°C) with a 20-90% relative humidity (non-condensing).

**LISTINGS:** Certified to UL1012 and CSA C22.2 No 107.1 by Intertek Testing Services for Dry Location.

### SPECIFICATIONS – EMI FILTER

**MECHANICAL:** Sealed plated steel construction with removable shielded cover for input connections through (3) 7/8" knock-outs. Rear-facing NPT threaded conduit pipe for output connections via flexible cable.

**ELECTRICAL:** 30A maximum rating. Min. 100dB common-mode attenuation between 5 MHz and 10 GHz. <1% voltage drop at rated current.

**INSTALLATION:** Filter must be installed in direct-contact with the exterior wall of the MRI shield enclosure using provided hardware. The power supply and EMI filter should be installed as close together as possible.

**LISTINGS:** cULus Listed to UL1012.

**INSTALLATION NOTE:** All power and signal wiring must be completely shielded in grounded conduit. The total length of low-voltage supply wires, at least 18AWG, should not exceed a total length of 50 feet (15m) between the power supply, filter and luminaires. See individual Kenall MRI luminaire specification sheets for additional information.

### ELECTRICAL SPECIFICATIONS

	MRIPSF-480	MRIPSF-240	MRIPSF-120
Output Wattage	480W	240W	120W
Maximum Output Current	20A	10A	5A
Input Voltage	120-277VAC	120-277VAC	120-277VAC
Typical Input Current	5.5A-120V / 2.0A-277V	4.0A-120V / 1.2A-277V	1.4A-120V / .55A-277V
Power Factor (at 50% load or greater)	> 90%	> 85%	> 86%
THD (at 50% load or greater)	< 15%	< 15%	< 21%
Min. efficiency at loads greater than 50%	92%	90%	90%
Cold Start Inrush Current (at 230VAC)	35A ( $T_{\text{WIDTH}}=1800\mu\text{s}$ MEASURED AT 50% $I_{\text{PEAK}}$ )	75A ( $T_{\text{WIDTH}}=570\mu\text{s}$ MEASURED AT 50% $I_{\text{PEAK}}$ )	60A ( $T_{\text{WIDTH}}=375\mu\text{s}$ MEASURED AT 50% $I_{\text{PEAK}}$ )



### ORDERING INFORMATION (Ex: MRIPSF-240)

Model

#### Model

**MRIPSF-120** 120 Watt Power Supply with EMI Filter  
**MRIPSF-240** 240 Watt Power Supply with EMI Filter  
**MRIPSF-480** 480 Watt Power Supply with EMI Filter



www.kenall.com | P: 800-4-Kenall | F: 262-891-9701 | 10200 55th Street Kenosha, Wisconsin 53144, USA

This product complies with the Buy American Act: manufactured in the United States with more than 50% of the component cost of US origin. It may be covered by patents found at www.kenall.com/patents. Content of specification sheets is subject to change; please consult www.kenall.com for current product details. ©2022 Kenall Mfg. Co.

A brand of **Legrand**

MRIPSF-041822

# MEDMASTER™ MRI REMOTE POWER SUPPLY/FILTER SYSTEM

## MRIPSF SERIES

### MRI LUMINAIRES CONNECTION PER POWER SUPPLY

PRODUCT	LAMP POWER	AMPS PER LUMINAIRE	MAX. LUMINAIRES PER POWER SUPPLY (MRIPSF-480)	MAX. LUMINAIRES PER POWER SUPPLY (MRIPSF-240)	MAX. LUMINAIRES PER POWER SUPPLY (MRIPSF-120)
CSMRI-22	6L	0.41	48	24	12
CSMRI-24	13L	0.76	26	13	6
CSMRI-44	26L	1.46	13	6	3
LPS5MRI-12 / LPSR5MRI-12	13L	0.76	26	13	6
ME11MRI	24L	1.46	13	6	3
MRIAUC	14L	0.76	26	13	6
	27L	1.52	13	6	3
MRIDL6	13L	0.77	26	13	6
	23L	1.29	15	7	3
	31L	1.82	11	5	2
MRIDL4 / MRIDL4S	13L	0.77	26	13	6
MRIMAS-813	6L	0.41	48	24	12
	14L	0.76	26	13	6
MRIMAS-826	19L	1.17	17	8	4
MRIMAS-838	25L	1.52	13	6	3
MRIMAS-850	32L	1.93	10	5	2
MRIGT-22	23L	1.29	15	7	3
	45L	2.58	7	3	1
MRT-24 / MRIGT-24	45L	2.58	7	3	1
	60L	3.63	5	2	1

NOTE: Multiple Kenall MRI product types may be powered from a single power supply/filter as long as the maximum current rating (see Electrical Specifications chart) is not exceeded.

### DIMENSIONAL DATA

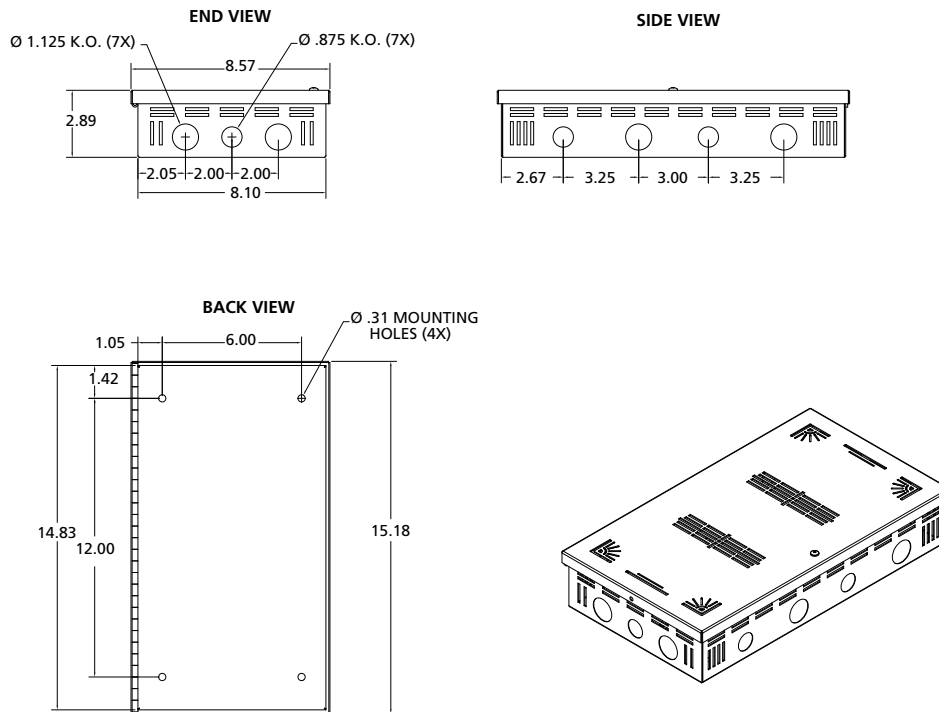

www.kenall.com | P: 800-4-Kenall | F: 262-891-9701 | 10200 55th Street Kenosha, Wisconsin 53144, USA

This product complies with the Buy American Act: manufactured in the United States with more than 50% of the component cost of US origin. It may be covered by patents found at [www.kenall.com/patents](http://www.kenall.com/patents). Content of specification sheets is subject to change; please consult [www.kenall.com](http://www.kenall.com) for current product details. ©2022 Kenall Mfg. Co.

A brand of **legrand**

MRIPSF-041822

**MRIPSF SERIES**

**IMPORTANT SAFEGUARDS**

When using electrical equipment, basic safety precautions should always be followed, including the following:

THIS PRODUCT MUST BE INSTALLED IN ACCORDANCE WITH THE APPLICABLE INSTALLATION CODE BY A PERSON FAMILIAR WITH THE CONSTRUCTION AND OPERATION OF THE PRODUCT AND THE HAZARDS INVOLVED. DISCONNECT POWER TO ALL CIRCUITS BEFORE WIRING FIXTURE. INSTALL IN ACCORDANCE WITH ALL NATIONAL, STATE, AND LOCAL CODES. DO NOT CONNECT TO AN UNGROUNDED SUPPLY. READ ALL FIXTURE MARKINGS AND LABELS TO ENSURE CORRECT INSTALLATION OF FIXTURE. SUPPLEMENTAL INSTRUCTIONS MAY BE LOCATED ON THE FIXTURE, IN ADDITION TO THIS INSTRUCTION SHEET, REGARDING ORIENTATION, OR MOUNTING RESTRICTIONS.

**SAVE THESE INSTRUCTIONS**

**INSTALLATION INSTRUCTIONS**

This instruction sheet applies to the Kenall MRIPSF Remote Power Supply & EMI Filter System. It describes the proper mounting and wiring procedure for a typical MRI room application. A separate instruction sheet is provided with the MRI luminaire(s). Both sheets together are intended to provide comprehensive instructions on system installation and electrical wiring.

The remote supply & EMI filter must be installed outside the shielded MRI environment. It contains ferrous components that can damage or interfere with MRI equipment. Complete conduit runs and wiring between power supply, EMI filters and luminaires after all system components have been installed in their final positions. If luminaires are intended to be dimmed (via 0-10V dimming system), then the Kenall MRIFD-1A EMI filter (or equivalent) must be ordered and installed.

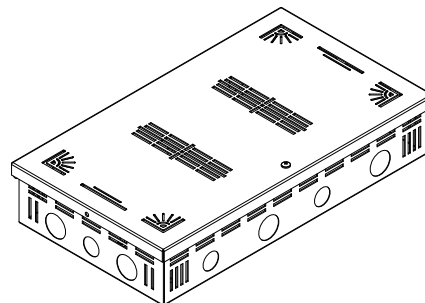
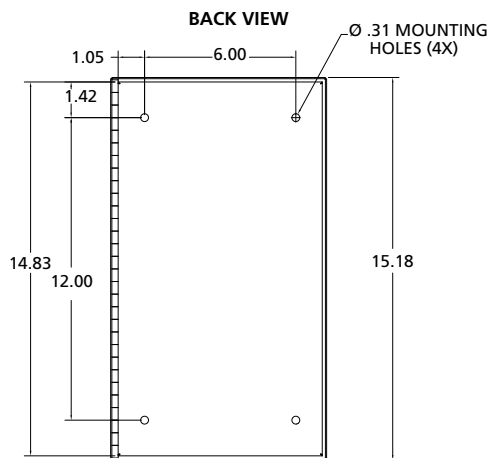
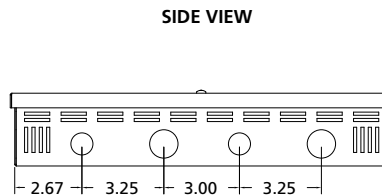
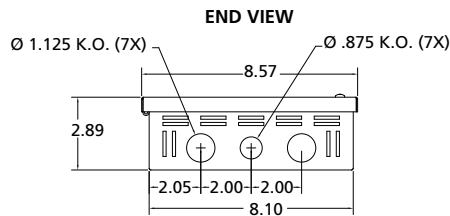

## Power Supply Mounting Procedure

1. Locate a suitable mounting location for the AC-DC power supply/supplies. The location should be chosen based on the following requirements:
  - A. Ambient Temperature/Humidity:** The surrounding ambient temperature must stay below 104°C (40°C). Allowable relative humidity is 20-90% non-condensing. Product is for DRY locations only.
  - B. Wire Distance:** The length of 24VDC supply wires between the power supply, EMI filter and luminaires should not exceed 50 feet (15m). This is the distance to the last luminaire within the run.
  - C. Ventilation:** Maintain at least 3" of free-air space around all sides of the power supply enclosure.
  - D. Contaminants:** Location should not allow excessive dirt/dust accumulation, preventing air circulation in and around the enclosure.
2. Securely mount the enclosure to a mechanically-sound surface. Use hardware appropriate for the weight of the enclosure and mounting surface type (not provided).

## 24VDC EMI Filter Mounting Procedure

1. Mount the provided 30-amp DC line EMI filter directly to outer enclosure wall via rear NPT conduit pipe using all provided gasketing and hardware (1-5/16" diameter hole size). See Figure 1. The power supply and EMI filter should be installed as close together as possible.

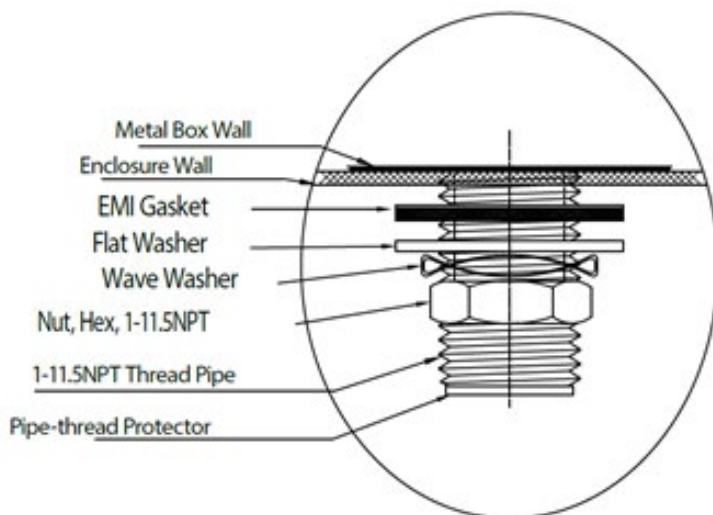

Figure 1: Filter Mounting Detail

**NOTE:** Filter mounting surfaces must be clean, free of paint and have suitable conductive finish for maximum grounding, shielding and provide isolation between input and termination connections.

2. Run grounded ½" conduit, with proper size conduit fittings, between the power supply and the input of the EMI filter. Make sure all gaps, regardless of size, are closed or wrapped in copper foil tape.



## 0-10V Dimming Filter Mounting Procedure (ordered separately from Power Supply/EMI Filter)

1. Mount the Kenall MRIFD-1A dimming-line filter directly to outer enclosure wall via rear NPT conduit pipe using all provided gasketing and hardware (1-5/16" diameter hole size). See Figure 1 for details.
2. Run grounded ½" conduit, with proper size conduit fittings, between the dimmer/controller and the input of the EMI filter. Make sure all gaps, regardless of size, are closed or wrapped in copper foil tape.

**NOTE:** The 0-10V dimmer must be installed *outside* the shielded MRI environment.

## Wiring Procedure - Single Power Supply DC Filter

Use the following procedure if **only one** power supply and DC EMI filter are to be connected in this installation. Refer to "Wiring Procedure - Multiple Power Supply/DC Filters" for multiple power supply installations. The overall system schematic is shown within Figure 2.

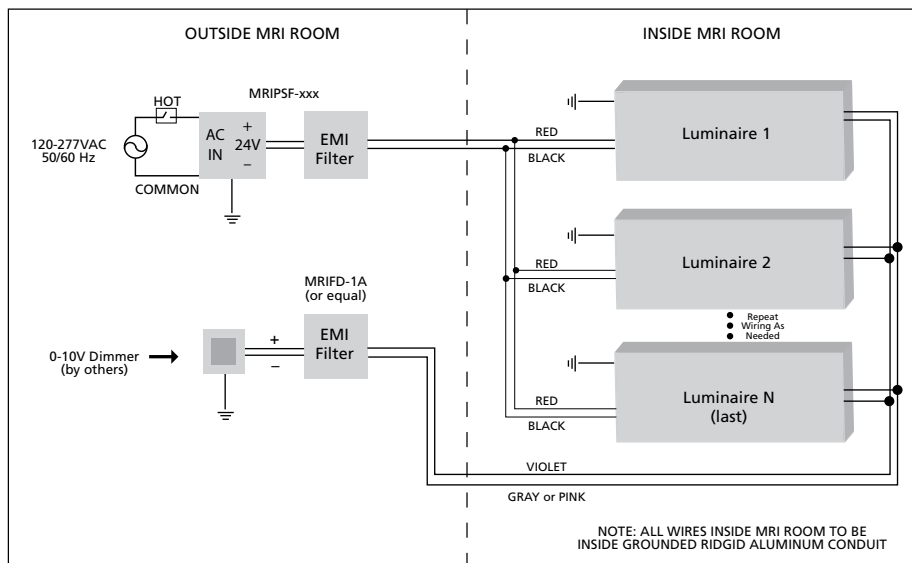

Figure 2: Single-Supply System Schematic

1. Make 120-277VAC, 50/60Hz supply connections on the line voltage side of the power supply. Make sure a proper ground is connected.
2. Run DC wiring (supplied by others), sized for the maximum output amperage listed on power supply nameplate, from the power supply to the DC EMI filter through the grounded conduit installed during the "24VDC EMI Filter Mounting Procedure".

**WARNING: To prevent electrical shock, manually discharge the internal filter capacitors by temporarily connecting field terminals to ground (wearing insulated gloves is recommended).**

3. Remove loose hardware supplied on filter field terminal screws and install power cables to each terminal through a crimped or solder-type ring connector (not supplied) using the supplied hardware. See Figure 3.
4. Remove loose hardware supplied on the ground screw terminal marked with the Green label and install a ground wire identical in size and insulation rating to the grounded and ungrounded circuit supplied conductor, except it shall be colored Green or Green-Yellow. Use a crimped or solder-type ring connector (not supplied, see Figure 3). The ground wire shall be installed as part of the circuit that supplies the filter.



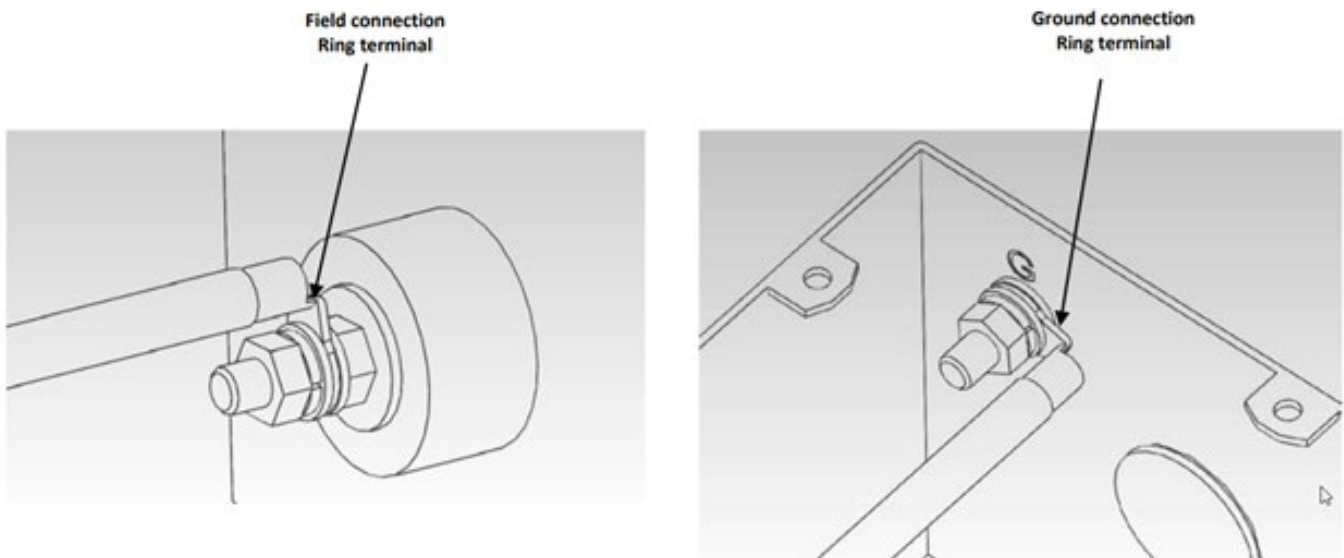

Figure 3: Ring Terminal Connections within EMI Filter

**NOTE:** Pressure terminal or pressure splicing connectors and solder lugs shall be the same or suitable materials as the conductors.

5. Fasten field and ground terminal hardware to a recommended torque of 18 lb-in.
6. Run DC wiring, equal in size and temperature rating to the filter input wiring, between the filter output cables and the first luminaire within the shielded room. All wiring must be within completely-enclosed, grounded conduit suitable for an MRI environment. Any gaps, regardless of size, must be closed or wrapped in copper foil tape. Special attention should be paid to the wiring entry point into the shielded space. Class 1 wiring methods are required.
7. Make subsequent wiring connections to luminaires following any additional procedures described within the luminaire installation instructions.

**NOTE:** See the “Maximum Fixture Connection” section (page 6) for the maximum number of luminaires that can be connected to each power supply. Multiple Kenall MRI product types may be powered from a single power supply/filter if the maximum output amperage, found on power supply nameplate, is not exceeded.

8. If 0-10V dimming is to be connected, please complete installation at this time. Refer to “Wiring Procedure – Dimming Line” for wiring procedure.
9. Complete any remaining steps on luminaire installation.
10. Connect power on line voltage side and test system operation. Test operation of lighting system, including dimming functionality, during MRI machine idle mode and during scanning operations.
11. Fill out the Installation Registration Form and fax to Kenall at (262) 891-9701.

## Wiring Procedure – Multiple Power Supply/DC Filters

Installations involving many luminaires within a single shielded room may require multiple power supplies (and EMI filters) to handle the load. Please see “Maximum Fixture Connection” to determine if the application requires multiple supplies. Wiring guidelines are the same as the previous section, please see Figure 4 below.

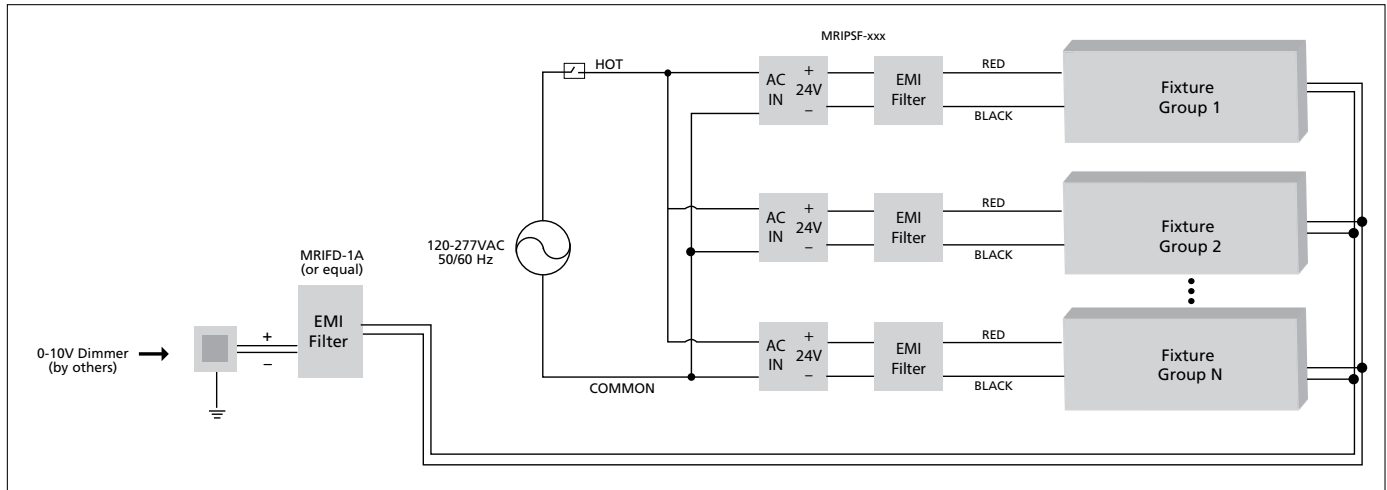

Figure 4: Multiple-Supply System Schematic

## Wiring Procedure – Dimming Line

All Kenall MRI luminaires can dim via 0-10V control. Kenall recommends the Lutron Diva (DVSTV) and Lutron Nova T (NTSTV-DV) series to ensure the full range of dimming can be achieved.

**NOTE:** In the situation where the luminaire groups are controlled by separate dimming circuits, it is imperative that each circuit utilizes a dedicated control line filter (Kenall MRIFD-1A or equivalent).

1. Run low-voltage wiring, 18-GA minimum, from the dimmer to the control line filter through the grounded conduit installed during the “0-10V Dimming Filter Mounting Procedure”.

**WARNING: To prevent electrical shock, manually discharge the internal filter capacitors by temporarily connecting field terminals to ground (wearing insulated gloves is recommended).**

2. Solder the dimming line positive (violet) and negative (gray or pink) conductor to solder terminal lugs L1 and L2, respectively.
3. Remove loose hardware supplied on the ground screw terminal marked with the Green label and install a ground wire identical in size and insulation rating to the grounded and ungrounded circuit supplied conductor, except it shall be colored Green or Green-Yellow. Use a crimped or solder-type ring connector (not supplied, see Figure 5).

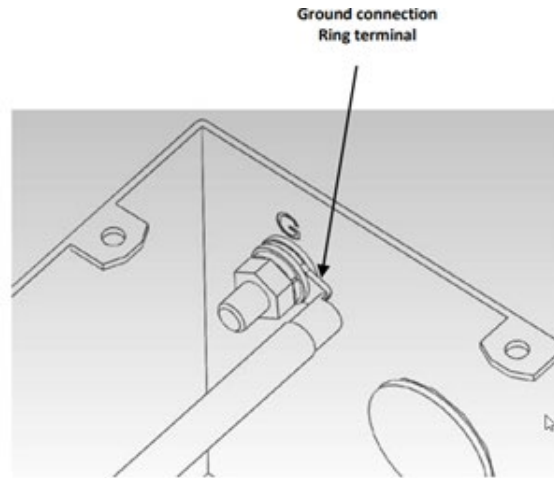

Figure 5: Signal Filter Ground Terminal

4. Fasten the ground terminal hardware to a recommended torque of 18 lb-in.
5. Run the signal wiring, equal in specification to the filter input wiring, between the filter output cables and the first luminaire within the shielded room. Maintain polarity between input and output sides of the filter. All wiring must be within completely-enclosed, grounded conduit suitable for an MRI environment. Any gaps, regardless of size, must be closed or wrapped in copper foil tape. Special attention should be paid to the wiring entry point into the shielded space.
6. Make subsequent wiring connections to luminaires following any additional procedures described within the luminaire installation instructions.